

LAMPIRAN

Tabel L- 1 Sifat fisik udara

894
FLUID MECHANICS

TABLE A-9

Properties of air at 1 atm pressure

Temp. $T, ^\circ\text{C}$	Density $\rho, \text{kg/m}^3$	Specific Heat c_p $\text{J/kg} \cdot \text{K}$	Thermal Conductivity $k, \text{W/m} \cdot \text{K}$	Thermal Diffusivity $\alpha, \text{m}^2/\text{s}$	Dynamic Viscosity $\mu, \text{kg/m} \cdot \text{s}$	Kinematic Viscosity $\nu, \text{m}^2/\text{s}$	Prandtl Number Pr
-150	2.866	983	0.01171	4.158×10^{-6}	8.636×10^{-6}	3.013×10^{-6}	0.7246
-100	2.038	966	0.01582	8.036×10^{-6}	1.189×10^{-6}	5.837×10^{-6}	0.7263
-50	1.582	999	0.01979	1.252×10^{-5}	1.474×10^{-5}	9.319×10^{-6}	0.7440
-40	1.514	1002	0.02057	1.356×10^{-5}	1.527×10^{-5}	1.008×10^{-5}	0.7436
-30	1.451	1004	0.02134	1.465×10^{-5}	1.579×10^{-5}	1.087×10^{-5}	0.7425
-20	1.394	1005	0.02211	1.578×10^{-5}	1.630×10^{-5}	1.169×10^{-5}	0.7408
-10	1.341	1006	0.02288	1.696×10^{-5}	1.680×10^{-5}	1.252×10^{-5}	0.7387
0	1.292	1006	0.02364	1.818×10^{-5}	1.729×10^{-5}	1.338×10^{-5}	0.7362
5	1.269	1006	0.02401	1.880×10^{-5}	1.754×10^{-5}	1.382×10^{-5}	0.7350
10	1.246	1006	0.02439	1.944×10^{-5}	1.778×10^{-5}	1.426×10^{-5}	0.7336
15	1.225	1007	0.02476	2.009×10^{-5}	1.802×10^{-5}	1.470×10^{-5}	0.7323
20	1.204	1007	0.02514	2.074×10^{-5}	1.825×10^{-5}	1.516×10^{-5}	0.7309
25	1.184	1007	0.02551	2.141×10^{-5}	1.849×10^{-5}	1.562×10^{-5}	0.7296
30	1.164	1007	0.02588	2.208×10^{-5}	1.872×10^{-5}	1.608×10^{-5}	0.7282
35	1.145	1007	0.02625	2.277×10^{-5}	1.895×10^{-5}	1.655×10^{-5}	0.7268
40	1.127	1007	0.02662	2.346×10^{-5}	1.918×10^{-5}	1.702×10^{-5}	0.7255
45	1.109	1007	0.02699	2.416×10^{-5}	1.941×10^{-5}	1.750×10^{-5}	0.7241
50	1.092	1007	0.02735	2.487×10^{-5}	1.963×10^{-5}	1.798×10^{-5}	0.7228
60	1.059	1007	0.02808	2.632×10^{-5}	2.008×10^{-5}	1.896×10^{-5}	0.7202
70	1.028	1007	0.02881	2.780×10^{-5}	2.052×10^{-5}	1.995×10^{-5}	0.7177
80	0.9994	1008	0.02953	2.931×10^{-5}	2.096×10^{-5}	2.097×10^{-5}	0.7154
90	0.9718	1008	0.03024	3.086×10^{-5}	2.139×10^{-5}	2.201×10^{-5}	0.7132
100	0.9458	1009	0.03095	3.243×10^{-5}	2.181×10^{-5}	2.306×10^{-5}	0.7111
120	0.8977	1011	0.03235	3.565×10^{-5}	2.264×10^{-5}	2.522×10^{-5}	0.7073
140	0.8542	1013	0.03374	3.898×10^{-5}	2.345×10^{-5}	2.745×10^{-5}	0.7041
160	0.8148	1016	0.03511	4.241×10^{-5}	2.420×10^{-5}	2.975×10^{-5}	0.7014
180	0.7788	1019	0.03646	4.593×10^{-5}	2.504×10^{-5}	3.212×10^{-5}	0.6992
200	0.7459	1023	0.03779	4.954×10^{-5}	2.577×10^{-5}	3.455×10^{-5}	0.6974
250	0.6746	1033	0.04104	5.890×10^{-5}	2.760×10^{-5}	4.091×10^{-5}	0.6946
300	0.6158	1044	0.04418	6.871×10^{-5}	2.934×10^{-5}	4.765×10^{-5}	0.6935
350	0.5664	1056	0.04721	7.892×10^{-5}	3.101×10^{-5}	5.475×10^{-5}	0.6937
400	0.5243	1069	0.05015	8.951×10^{-5}	3.261×10^{-5}	6.219×10^{-5}	0.6948
450	0.4880	1081	0.05298	1.004×10^{-4}	3.415×10^{-5}	6.997×10^{-5}	0.6965
500	0.4565	1093	0.05572	1.117×10^{-4}	3.563×10^{-5}	7.806×10^{-5}	0.6986
600	0.4042	1115	0.06093	1.352×10^{-4}	3.846×10^{-5}	9.515×10^{-5}	0.7037
700	0.3627	1135	0.06581	1.598×10^{-4}	4.111×10^{-5}	1.133×10^{-4}	0.7092
800	0.3289	1153	0.07037	1.855×10^{-4}	4.362×10^{-5}	1.326×10^{-4}	0.7149
900	0.3008	1169	0.07465	2.122×10^{-4}	4.600×10^{-5}	1.529×10^{-4}	0.7206
1000	0.2772	1184	0.07868	2.398×10^{-4}	4.826×10^{-5}	1.741×10^{-4}	0.7260
1500	0.1990	1234	0.09599	3.908×10^{-4}	5.817×10^{-5}	2.922×10^{-4}	0.7478
2000	0.1553	1264	0.11113	5.664×10^{-4}	6.630×10^{-5}	4.270×10^{-4}	0.7539

Note: For ideal gases, the properties c_p , k , μ , and Pr are independent of pressure. The properties ρ , ν , and α at a pressure P (in atm) other than 1 atm are determined by multiplying the values of ρ at the given temperature by P and by dividing ν and α by P .

Source: Data generated from the EES software developed by S. A. Klein and F. L. Alvarado. Original sources: Keenan, Chao, Keyes, Gas Tables, Wiley, 198; and Thermophysical Properties of Matter, Vol. 3: Thermal Conductivity, Y. S. Touloukian, P. E. Liley, S. C. Saxena, Vol. 11: Viscosity, Y. S. Touloukian, S. C. Saxena, and P. Hestermans, IFI/Plenum, NY, 1970, ISBN 0-306067020-8.

Tabel L- 2 Jadwal Penelitian

NO	Urutan Penelitian	Bulan ke-					
		I	II	III	IV	V	VI
1	Proposal						
2	Persiapan						
3	Pembuatan alat						
4	Pengambilan data						
5	Pengolahan data						
6	Seminar hasil						
7	Ujian						

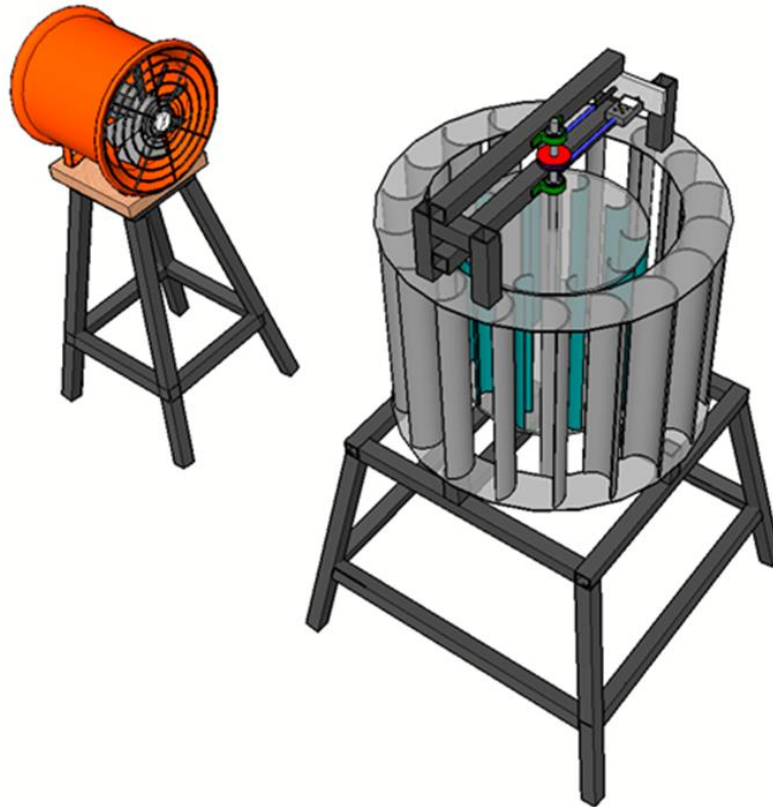

Gambar L. 1 Layout turbin angin *crossflow* 12 sudu dengan variasi jumlah sirip menggunakan *cylindrical guide vane*

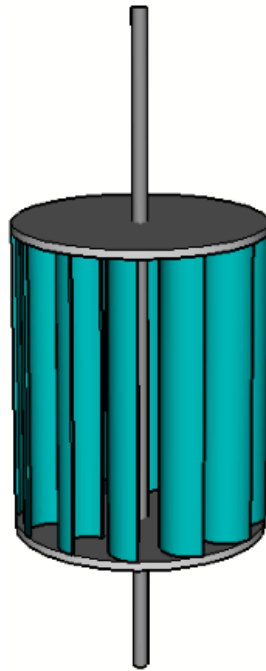

Gambar L. 2 Rotor turbin angin *crossflow* 12 Sudu tanpa sirip

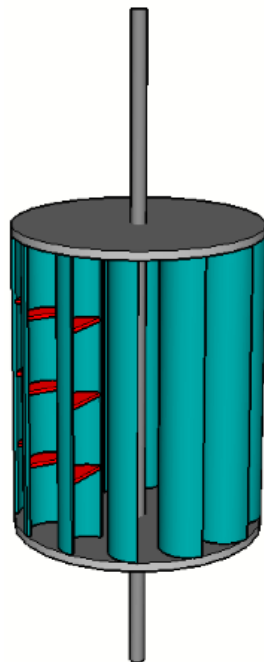

Gambar L. 3 Rotor turbin angin *crossflow* 12 sudu 3 sirip

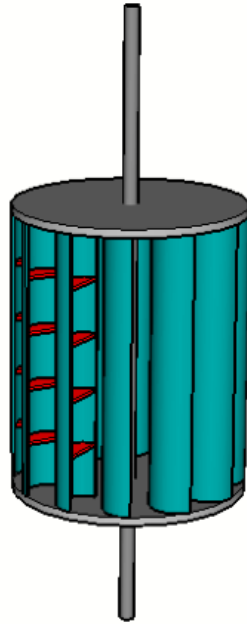

Gambar L. 4 Rotor turbin angin *crossflow* 12 sudu 4 sirip

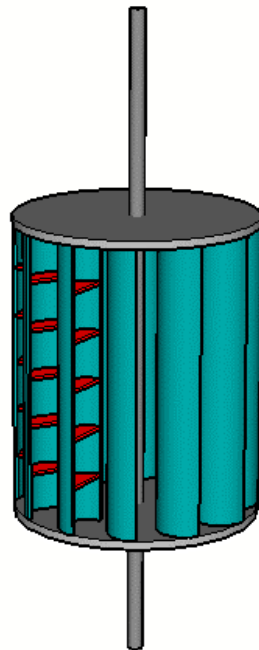

Gambar L. 5 Rotor turbin angin *crossflow* 12 sudu 5 sirip

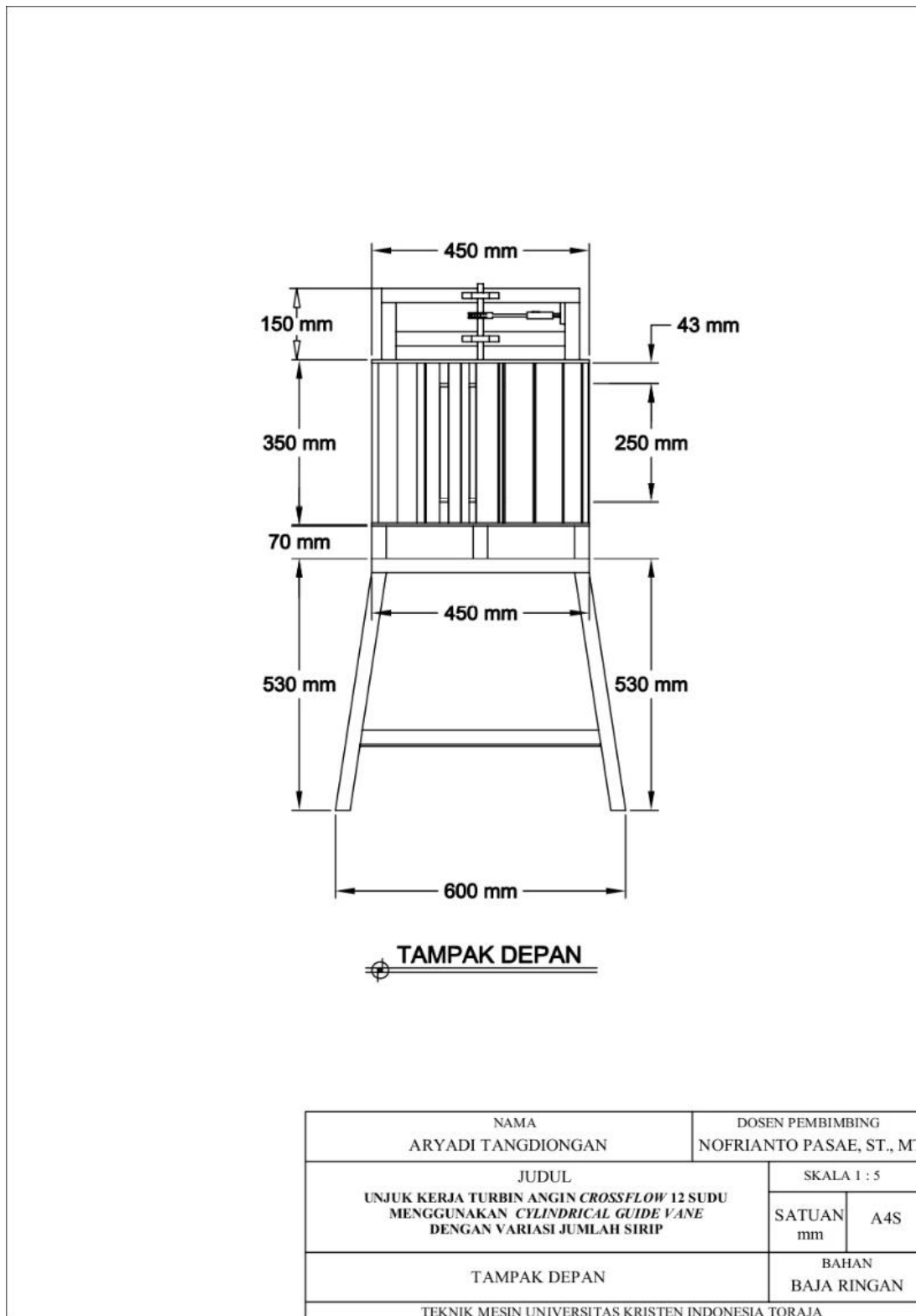

Gambar L. 6 Dimensi turbin angin *crossflow* tampak depan

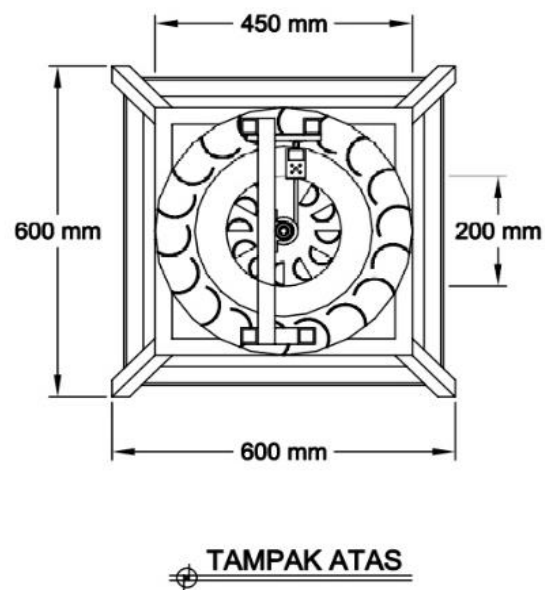

NAMA ARYADI TANGDIONGAN		DOSEN PEMBIMBING NOFRIANTO PASAE, ST., MT	
JUDUL UNJUK KERJA TURBIN ANGIN <i>CROSSFLOW</i> 12 SUDU MENGUNAKAN <i>CYLINDRICAL GUIDE VANE</i> DENGAN VARIASI JUMLAH SIRIP		SKALA 1 : 5	
		SATUAN mm	A4S
TAMPAK ATAS		BAHAN BAJA RINGAN	
TEKNIK MESIN UNIVERSITAS KRISTEN INDONESIA TORAJA			

Gambar L. 7 Dimensi turbin angin *crossflow* tampak atas

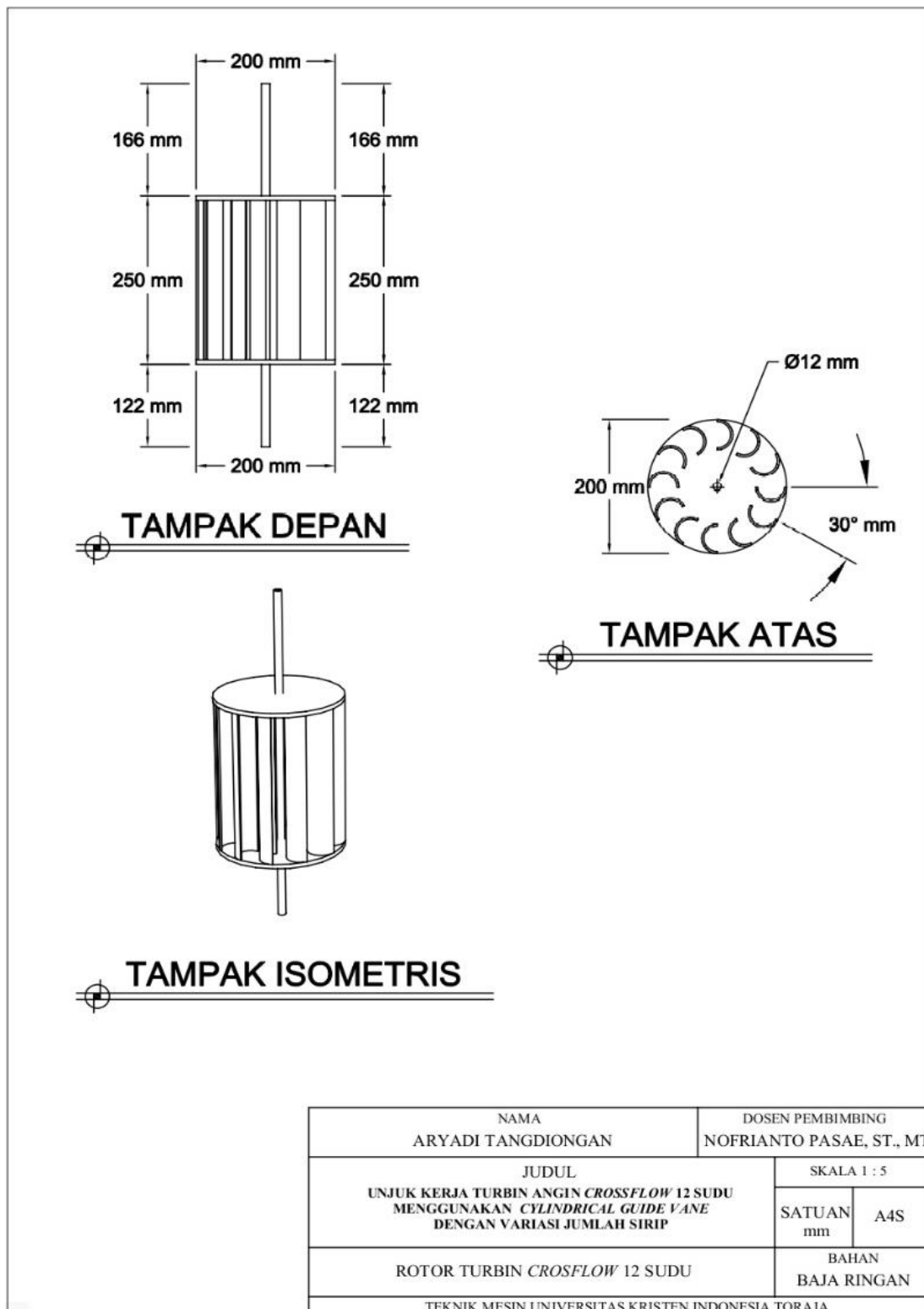
Gambar L. 8 Rotor turbin *crossflow* 3 sirip 12 sudu

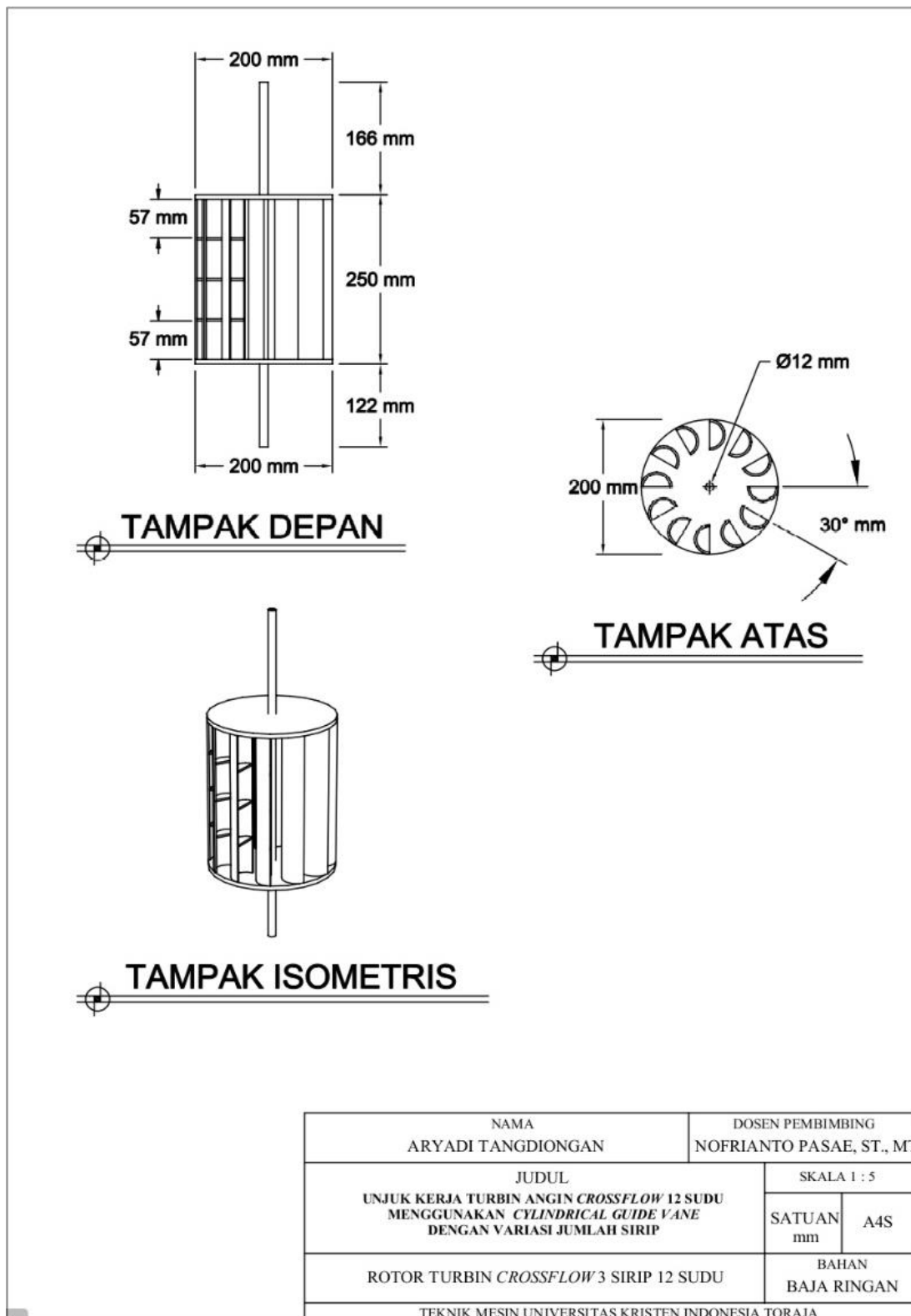
Gambar L. 9 Rotor turbin *crossflow* 3 sirip 12 sudu

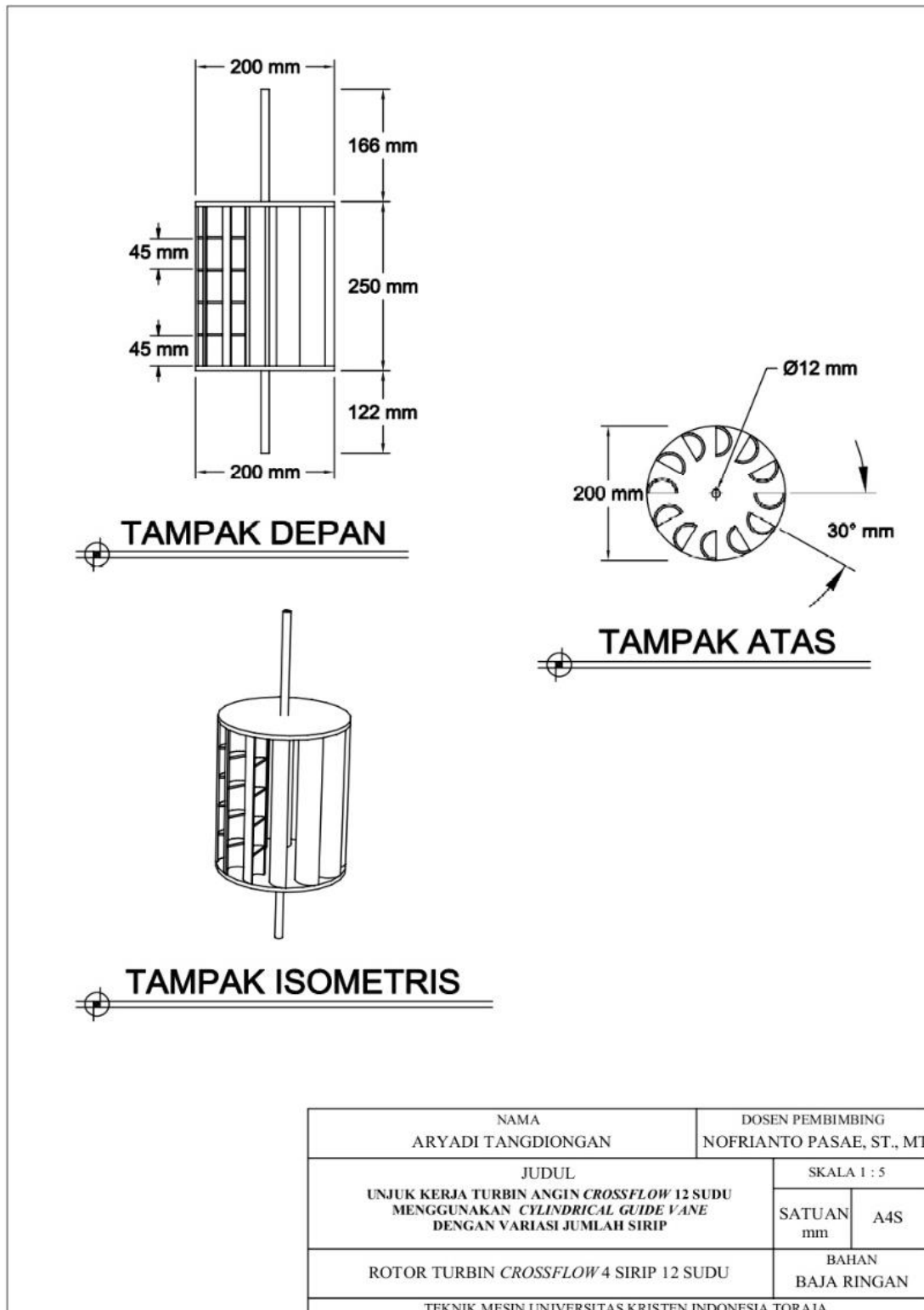
Gambar L. 10 Rotor turbin *crossflow* 4 sirip 12 sudu

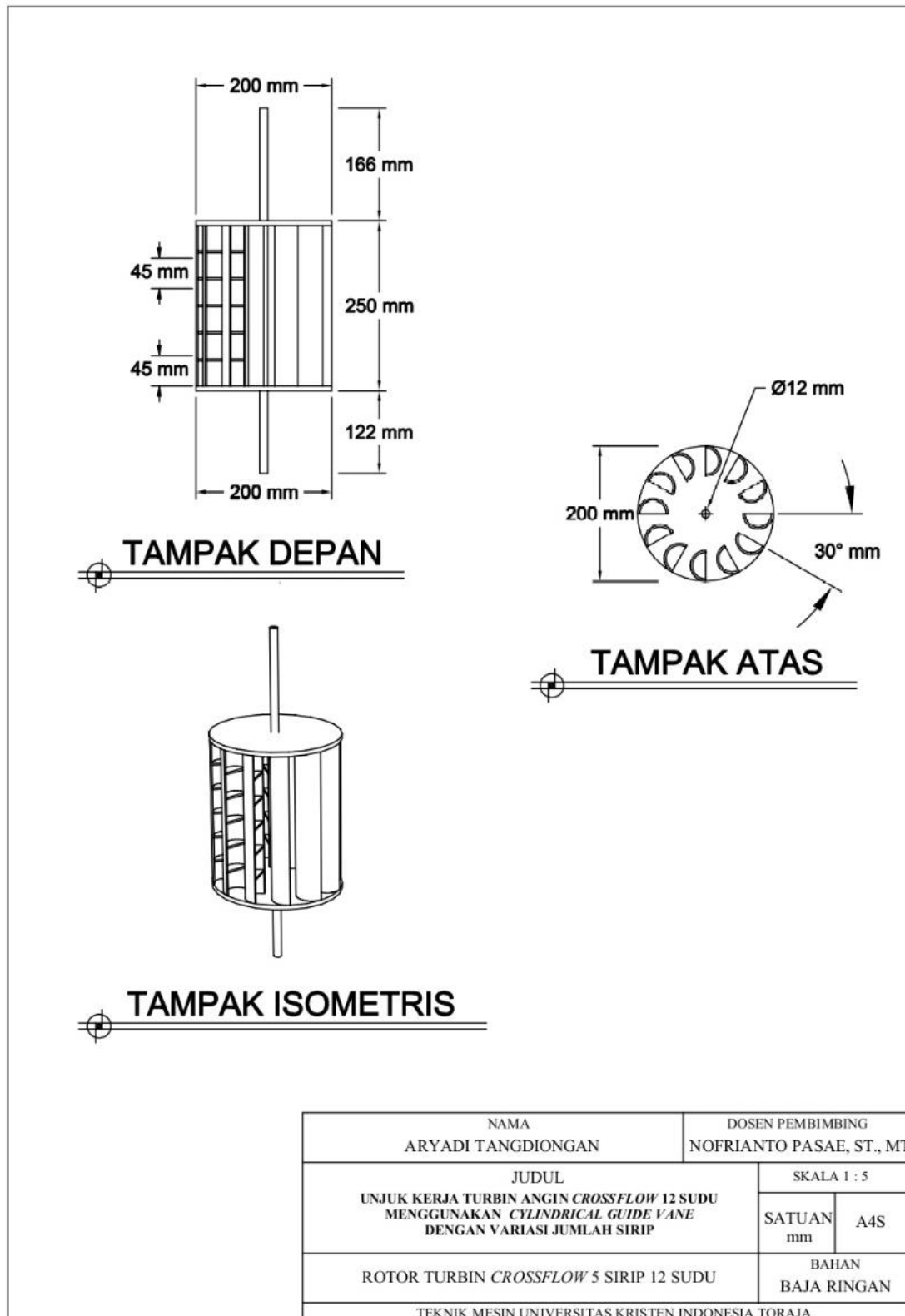

Gambar L. 11 Rotor turbin *crossflow* 5 sirip 12 sudu

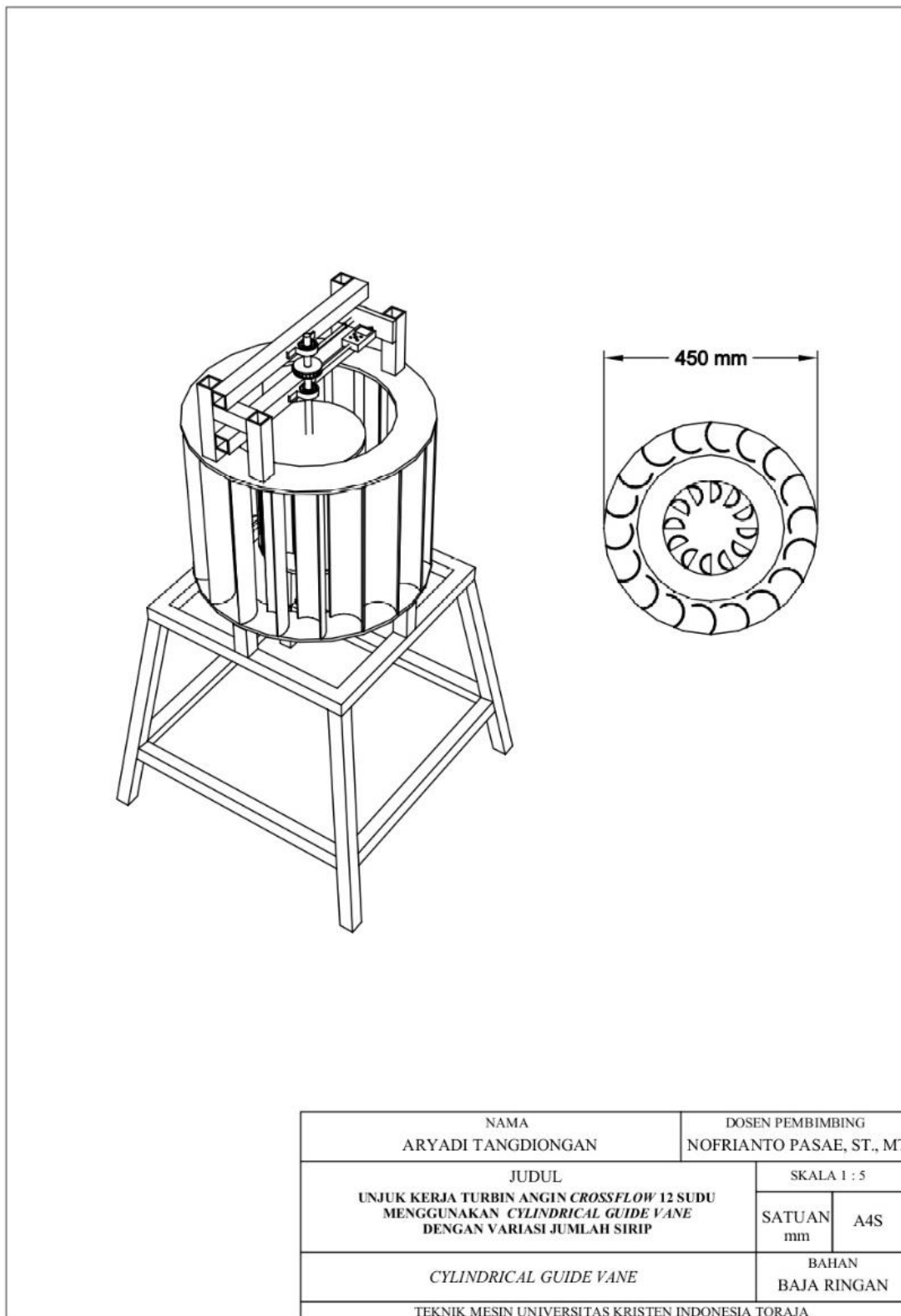
Gambar L. 12 *Cylindrical guide vane*



Gambar L. 13 Thacometer.



Gambar L. 14 Anemometer



Gambar L. 15 Neraca digital



Gambar L. 16 Timbangan digital



Gambar L. 17 *Blower*



Gambar L. 18 Pemasangan sudu dan sirip



Gambar L. 19 Rotor dan *Cylindrical guide vane* setelah pengeleman



Gambar L. 20 Pengelasan Rangka



Gambar L. 21 Penghalusan rangka



Gambar L. 22 Pemasangan rotor dan *Cylindrical guide vane*



Gambar L. 23 Pengetesan alat



Gambar L. 24 Turbin angin crossflow 12 sudu menggunakan *Cylindrical guide vane*



Gambar L. 25 Pengambilan data



Gambar L. 26 Pengambilan data